

# Pulse Rate Monitoring Alert via SMS.

Mr. AmolGosavi | Mr. DnyaneshwarKandekar | Mr. Nikhil Ghadge | Mr. Anurag Behere

Prof. D. R. Patil

JayawantraoSawant College of Engineering, Hadapsar Pune-28, SavitribaiPhule Pune University, Pune, India.

gosaviamol1995@gmail.com | dnyaneshwarkandekar@gmail.com  
[ghadgenikhil094@gmail.com](mailto:ghadgenikhil094@gmail.com) | [apgreatsunna9@gmail.com](mailto:apgreatsunna9@gmail.com)  
drpatil2009@gmail.com

**Abstract—** Health related concerns and parameters are of utmost importance to man, and is essential to his existence and influence and thus he has sought for an improved system that would be able to capture and monitor the changes in health parameters irrespective of time and location so as to provide for measures that will predict anomalies and cater for emergencies. This work presents a system that is capable of providing real time remote monitoring of the pulse rate with improvements of an alarm and SMS alert. This project aims at the design and implementation of a low cost but efficient and flexible pulse rate monitoring and alert system using GSM technology. It is designed in such a way that the pulse rate is sensed and measured by the sensors which sends the signals to the control unit for proper processing and determination of the pulse rate which is displayed on an LCD, it then proceeds to alert by an alarm and SMS sent to the mobile phone of the medical expert or health personnel, if and only if the threshold value of the pulse rate is maximally exceeded. Thus this system proposes a continuous, real time, remote, safe and accurate monitoring of the pulse rate and helps in patient's diagnosis and early and preventive treatment of cardiovascular ailments.

**Keywords—** pulse rate; photoplethysmograph; SMS; Microcontroller

## I. INTRODUCTION

Cardiovascular disease is one of the main reasons of death in many countries and thus it accounts for the over 15 million deaths worldwide. In addition, several million people are disabled by cardiovascular disease. The delay between the first symptom of any cardiac ailment and the call for medical assistance has a large variation among different patients and can have fatal consequences. One critical implication drawn from epidemiological data is that deployment of resources for early detection and treatment of heart disease has a higher potential of reducing fatality associated with cardiac disease than improved care after hospitalization. Hence new strategies are needed in order to reduce time before treatment. Monitoring of patients is one possible solution. Also, the trend towards an independent lifestyle has also increased the demand for personalized non-

hospital based care. Cardiovascular disease has shown that heart beat rate plays a key role in the risk of heart attack. Heart disease such as heart attack, coronary heart disease, congestive heart failure, and congenital heart disease is the leading cause of death for men and women in many countries. Most of the time, heart disease problems harm the elderly person. Very frequently, they live with their own and no one is willing to monitor them for 24 hours a day.

In this proposed device, the heart beat and temperature of patients are measured by using sensors as analog data, later it is converted into digital data using analog to digital converter (ADC) which is suitable for wireless transmission using SMS messages through GSM modem. Micro controller device is used for temporary storage of the data used for transmission. For a patient who is already diagnosed with fatal heart disease, their heart rate condition has to be monitored continuously. This project proposes and focuses on the design of the pulse rate monitor that is able to monitor the heart beat rate condition of patient continuously. This signal is processed using the microcontroller to determine the heart beat rate per minute. Then, it sends short message service (SMS) alert to the mobile phone of medical experts or patients family members, or their relatives about the condition of the patient and abnormal details via SMS. Thus, doctors can monitor and diagnose the patients condition continuously and could suggest earlier precaution for the patients themselves. This will also alert the family members to quickly attend to the patient. The remote pulse rate monitor proposed in this work can be used in hospitals and also for patients who can be under continuous monitoring while traveling from place to place, since the system is constantly monitoring the patient.

## II. PROPOSED SYSTEM

Block diagram of proposed system is shown in Fig.1. In this module, 12V and 5V power supply given to GSM modem and other devices respectively.

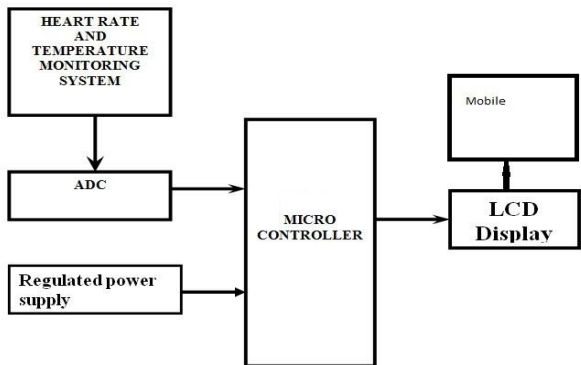

Figure 3.1 General Architecture of proposed Framework

### III. RELATED WORK

Heart beat sensor is designed to give digital output of heart beat when a finger is placed on it. When the heart beat detector is working, the beat LED flashes in unison with each heartbeat. This digital output can be connected to microcontroller directly to measure the Beats Per Minute (BPM) rate. It works on the principle of light modulation by blood flow through finger at each pulse.

#### A. PIC Controller

In 1989, Microchip Technology Corporation introduced an 8-bit microcontroller called the PIC. PIC stands for Peripherals Interface Controller [1]. PIC16F877A is high performance RISC processor. PIC controller processes the outputs of sensor circuits. The small compact size combined with easy program updates and modifications. PIC16F877A is use in machinery and control system.

#### Specifications:-

- Clock input required to PIC controller is DC-20MHz.
- ADC is 10 bit, up to 8-channel ADC.
- Flash program memory is up to 8K\*14 words.
- Data memory is up to 368\*8 bytes.
- EEPROM data memory is up to 256\*8 bytes.
- Timers are Timer0- 8 bit timer/counter, Timer1- 16 bit timer/counter, Timer2- 8 bit timer/counter.

#### B. Pulse Rate Sensor

Heart rate sensor gives digital output of heart rate when a finger is placed on it. The beat LED on sensor is flashes with pulse rate, when the heart beat detector is working. The output of sensor is then connected to PIC controller directly to measure the Beats per Minute (BPM) rate. It

works on the principle of light modulation by blood flow through finger at each pulse.

#### Specifications:-

- Operating voltage is +5V DC regulated.
- Operating current is 100 mA.
- Output data levels are 5V TTL level.
- LED is use to Heart beat detection and Output High Pulse.
- Light source are 660nm Super Red LED.

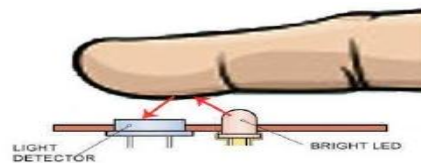

Figure.2 Hearts Rate Sensor

Serial data communication needs often dictate the frequency of the oscillator because of the requirement that internal counters must divide the basic clock rate to yield standard communication baud rates



Figure 3.3 serial communication port

CP2101 chip is used to communicate with PC USB port which creates the com port for communication with PC. CP2102 is a single chip USB to UART bridge IC. It requires minimal external components. CP2102 can be used to migrate legacy serial port based devices to USB. Hobbyists can use it as a powerful tool to make all kinds of PC interfaced projects. This module help all those who are comfortable with RS232/Serial Communication protocol, to build USB devices very easily.

## VI. CONCLUSION

The key objective of developing this module is to alert medical advisory about present health condition of patient via SMS. The buzzer will turn ON when body temperature and heart rate exceeds or below the threshold level. It accomplishes the objective to measure the heart rate and body temperature. This module is advantageous where continuous monitoring of patient is required under critical condition. This module is applicable in Hospitals, homes and also in ambulances. But for this module, For SMS requires mobile phone. Message cannot be send to medical advisory without network coverage.

## VII. ACKNOWLEDGMENT

We are using this opportunity to express our gratitude to everyone who supported us for writing this paper. We are thankful for their guidance and invaluable advice during this work. We are sincerely grateful to them for sharing their truthful and illuminating views on a number of issues related to this paper

## REFERENCES

- [1] Instant Notification System In Heterogeneous Sensor Network With Deployment Of XMPP Protocol Ms.SonaR.Pawara Department of Computer Engg., STES's Sinhgad Academy of Engineering, Kondhwa(Bk) Pune, India srpawara.sae@sinhgad.edu Mrs. Swapnaja R. Hiray Department of Computer Engg., STES's Sinhgad College of Engineering, Vadgaon(Bk) Pune, India swapnajahiray@gmail.com
- [2] D. Rehunathan, S. Bhatti, O. Chandran, and P. Hui, "vNurse: Using virtualisation on mobile phones for remote health monitoring," in 13th IEEE Intl. Conf. on e-Health Networking Applications and Services (HealthCom). IEEE, 2011, pp. 82–85.
- [3] Ch. Sandeep Kumar Subudhi, S.Sivanandam, "Intelligent Wireless Patient Monitoring and Tracking System (Using Sensor Network and Wireless Communication)", International Journal of Interdisciplinary and Multidisciplinary Studies, Page No.-97-104, Volume 1, Issue 2014.
- [4] R.Aravind, Syed Musthak Ahmed, "Design of Family Health Care Monitoring System Using Wireless Communication Technology", International Journal of Advanced Research in Computer and Communication Engineering, Page No.-3666-3671 volume 2, Issue 9 September 2013
- [5] Sudhindra.F, Annarao.S.J, Vani.R.M, P.V. Hunagund, "A GSM Enabled Real Time Simulated Heart Rate Monitoring & Control System", International Journal of Research in Engineering and Technology, Page No. 6-10 Volume: 03, special Issue: 0 May 2014.
- [6] Muhammad Ali MazidiRolind D. Mckinlay Danny causay, "PIC microcontroller and Embedded System", Edition second, Pearson publication
- [7] Remote Health Monitoring Using Online Social Media Systems ChonlateeKhorakhun University of St Andrews, UK ck46@cs.st-andrews.ac.uk Saleem N. Bhatti University of St Andrews, UK saleem@cs.st-andrews.ac.uk
- [8] A. Wood, G. Virone, T. Doan, Q. Cao, L. Selavo, Y. Wu, L. Fang, Z. He, S. Li n, J. Stankovic, "ALARM-NET: Wireless Sensor Network for Assisted Livinf And Residentail Monitoring," Technical Report-2006- 13,Department of Computer Science,University of Virginia
- [9] David Malan, Thaddeus FulfordJones, Matt Welsh, and Steve Moulton" CodeBlue: An Ad Hoc Sensor Network imfrastructure for Emergency Medical Care"