

## Smart Patients Monitoring System based on IoT

Dr. Vishal kumar chhimpa, Associate Professor  
Mr. Sandip Kumar Mitra, mitra.sandip@gmail.com

**Abstract:** *In the last decade the healthcare monitoring systems have drawn considerable attentions of the Researchers. The prime goal was to develop a reliable patient monitoring system so that the healthcare professionals can monitor their patients, who are either hospitalized or executing their normal daily life activities. In this work we present a mobile device based wireless healthcare monitoring system that can provide real time online information about physiological conditions of a patient. Our proposed system is designed to measure and monitor important physiological data of a patient in order to accurately describe the status of his/her health and fitness. The Internet of things is increasingly allowing to integrate devices capable of connecting to the Internet and provide information on the state of health of patients and provide information in real time to doctors who assist. It is clear that chronic diseases such as diabetes, heart and pressure among others, are remarkable in the world economic and social level problem. The aim of this article is to develop an architecture based on an ontology capable of monitoring the health and workout routine recommendations to patients with chronic diseases.*

**Keywords:** *Health care; ARM7, Sensors, IOT, Health Care Centers, Patient monitor Remote device, Biomedical device, ECG monitoring, Blood pressure, heartbeat rate.*

### 1. Introduction

In the field of health monitoring the current most important user groups are those aged 40 and more. The group of 40+ users shows more diversity in their health conditions than younger people. There are ring- type pulses monitoring sensor available in the market in which the measured data are displayed in the LCD and cannot be

transmitted out of the ring. Thus, it is not possible to continuously monitor the vital parameters such as temperature, pressure and pulse from a distant location. In a hospital either the nurse or the doctor has to move physically from one person to another for health check, which may not be possible to monitor their conditions continuously. Thus any critical situations cannot be found easily unless the nurse or doctor checks the person's health at that moment. This may be a strain for the doctors who have to take care of a lot number of people in the hospital. In such situations, remote patient monitoring using the bandwidth guaranteed internet services has been seen as a success factor in healthcare organizations. In order to keep in track of critical health conditions, a real time health monitoring system of patient based on Sensors, GSM, and SMS along with ad-hoc is designed and developed in this work. Wireless Ad-hoc Sensor Networks (WSN) are a class of networks that are deployed for sensing, processing and transferring a set of parameters in an infrastructure-less terrain, within certain requirements such as accuracy, latency and Network availability. These networks consist of a large number of wireless nodes that monitor, understand and possibly control a set of parameters in the physical world.

### 2. Related Work

There is Healthcare Monitoring system using WSN with Zigbee. But main drawback of this system is that we can monitor the patients for 100 meter distance only. There is Healthcare Monitoring system using WSN with GSM we can monitor the patients anywhere across the world. During the early 1980s, analog cellular telephone

system was experiencing rapid growth in Europe, particularly in Scandinavia and United Kingdom, but also in France and Germany. Each country developed its own system, which was incompatible with everyone else's in equipment and operation. This was an undesirable situation, because not only was the mobile equipment limited to operation within national boundaries, which in a unified Europe were increasingly unimportant, but there was also a very limited market for each type of equipment, so economies of scale and the subsequent savings could not be realized. The Europeans realized this early on, and in 1982 the conference of European posts and telegraphs formed a study group called the group special mobile (GSM) to study and develop a pan-European public land mobile system. The proposed system had to meet certain criteria. Good subjective speech quality. Low terminal and service cost supports for international roaming. Support for range of new services and facilities. In 1989, GSM responsibility was transferred to the European Telecommunication Standards Institute (ETSI), and phase I of the GSM specifications were published in 1990. Commercial service was started in mid-1991, and by 1993 there were 36 GSM networks in 22 countries, with 25 additional countries having already selected or considering GSM. Although standardized in Europe, GSM is not only a European standard. GSM networks are operational or planned in almost 60 countries in Europe, the Middle East, the Far East, Africa, South America, and Australia. In the beginning of 1994, there were 1.3 million subscribers worldwide. By the beginning of 1995, there were over 5 million subscribers. The acronym GSM now aptly stands for Global System for Mobile communications. The developers of GSM chose an unproven (at the time) digital system, as opposed to the then-standard analog cellular

systems like AMPS in the United States and TACS in the United Kingdom.

### 3. Existing System

There are some shortcomings present in existing system. Currently there are number of health monitoring systems available for the ICU patients which can be used only when the patient is on bed. This system is wired everywhere. The patient is monitored in ICU and the data transferred to the PC is wired. Such systems become difficult where the distance between System and PC is more. The available systems are huge in size. Regular monitoring of patient is not possible once he/she is discharged from hospitals. These systems cannot be used at individual level. The other problem with these systems is that it is not capable of transmitting data continuously also range limitations of different wireless technologies used in the systems. So to overcome these limitations of systems I have proposed a new system. This system is able to transmit the parameters of patient continuously and over long distance wirelessly. Due to which we would be able attend the patient immediately. Therefore by developing a system that can constantly measure the important parameters of patient's body and which can alert the closed ones and the doctor on any time when the patient's condition gets bad, this can really provide quick service and be beneficial in saving a lot of lives.

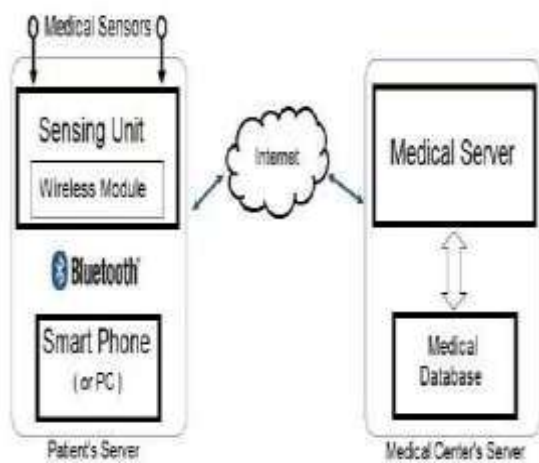

**Fig-1:** Existing System

### 4. Proposed System

The system which we proposed to develop shown in below figure would not only help in monitoring the patient when he is in the bed but also when he is not in the bed i.e. when he is mobile. Such a system would

constantly monitor important body parameters like temperature, heartbeat, ECG, Blood pressure and would compare it against a predetermined value set and if these values cross a particular limit it would automatically alert the doctor and relatives of the fulfillment of the original criteria and the continual improvement of the system in terms of quality and cost. The nearly 6000 pages of GSM recommendations try to allow edibility and competitive innovation among suppliers, but provide enough standardization to guarantee the proper interworking between the components of the system. This is done by providing functional and interface descriptions for each of the functional entities defined in the system. Patient via a buzzer, In such case the patient will get a very quick medical help and also would save time and energy of the relatives who would not be with them all the time. The proposed architecture is given in below figure. It is composed of an embedded sensing unit, a personal server (patient's smart phone or PC), a medical center server and a reliable wireless communication channel.



**Fig-2:** Health care monitoring system

#### 4.1 Embedded Sensing Unit

It is a microcontroller interfaced with

sensors and Bluetooth module for wireless communication with smart phone of the patient. The smart phone can be used to achieve wireless communication with the medical center through the internet. Direct communication can be achieved between the patient and his/her authorized doctor. The doctor can communicate with the patient medical case through the internet. In the proposed system we are using ARM (LPC2148) microcontroller which will reads the sensor information like temperature, blood pressure, heartbeat, saline level, ECG and position. An then the microcontroller analyze the data and make alert on exceeding the parameter. The proposed system also sends the information to the smart phone with the help of Bluetooth.

#### 4.2 Patient Server

The patient server receives biomedical data from the embedded sensing unit through Bluetooth wireless channel. The patient server offers a wireless communication channel between patient and the medical center server. It performs the following tasks;

- Collecting measured data and biomedical status from the embedded sensing unit.
- offering real-time display for biomedical
- Measurements and medical guidance sent from the doctor.

#### 5. Block Diagram

The block diagram of the proposed system is as shown in the figure bellow.

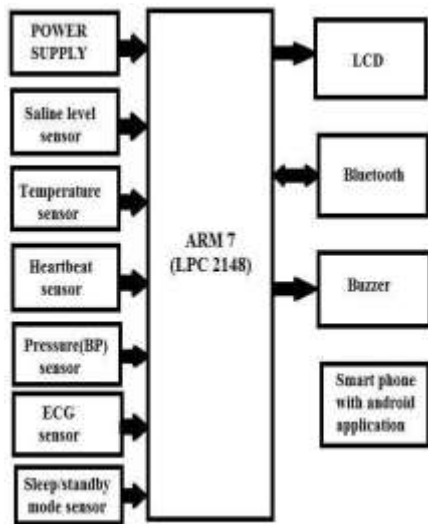

**Fig-3:** block diagram

### [1] ARM7 LPC 2148

ARM7 LPC21487 is one of the widely used microcontroller based on a 16-bit/32-bit ARM7TDMI-S CPU with real-time emulation and embedded support. LPC2148 is RISC based processor that uses fewer transistors than other typical processors. Hence it leads to low cost and low power consumption. In this work some sensors such as LM35 temperature sensor gives the analog data that need to be convert in to digital. Its 10-bit A/D converter provide digital output with respect to the voltage given by LM35 with conversion times as low as 2.44 us per channel. The power supply operating voltage range is from 3.0 V to 3.6 V.

### [2] Bluetooth

Here we are using the serial Bluetooth device HC-05 to communicate the coordinator to android device. It is a communication device over work is based on wireless communication between micro controller and mobile phone. But alone micro controller is not able to communicate directly to the android mobile phone. Bluetooth Serial module's operation doesn't need drive, and can communicate with the other Bluetooth device that has the serial. But communication between two Bluetooth modules requires at Least two

conditions:

- (1) The communication must be between master and slave.
- (2) The password must be correct.

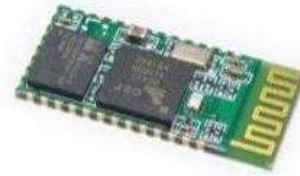

**Fig-4:** HC-05 Bluetooth

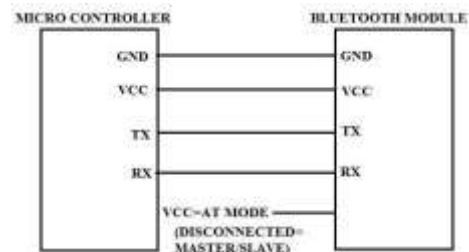
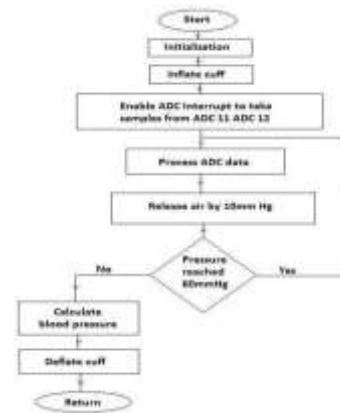

**Fig-5:** Typical application circuit

### [3] Temperature Sensor

A body temperature sensor type LM35 has been used in this design. The sensor is connected to an amplification circuit to ensure output voltage 5v as shown in below figure. The amplified signal can be connected to the ARM7 microcontroller, the amplifier gives an analog signal output than an ADC (Analog to Digital Converter) gives the digital output.





modulation by blood flow through finger at each pulse.

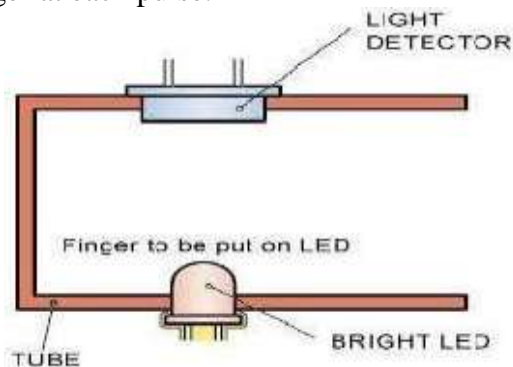

**Fig-10:** Overview of LM 358

ICLM358 is used for Heart Beat Sensor. Its dual low power operational amplifier consists of a super bright red LED and light detector. One will act as amplifiers and another will be used as comparator. LED needs to be super bright as the light must pass through finger and detected at other end. When heart pumps a pulse of blood through blood vessels, finger becomes slightly more opaque so less light reached at the detector. With each heart pulse detector signal varies this variation is converted to electrical pulse.

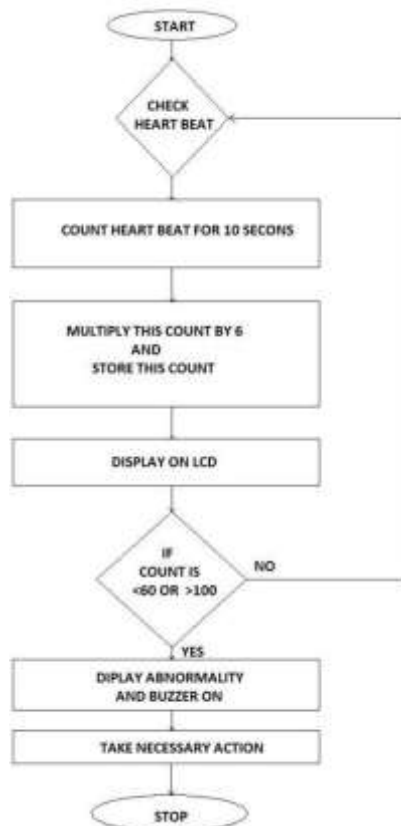

**Fig-11:** heartbeat measurement flowchart

### [7] Sleep/Standby Mode (ADXL 335) Sensor

In this section we will 3-Axis Accelerometer for identifying the patient state, it means whether the patient is sleep/standby mode. By using this sensor we can easily identifying the patient state. When the patient in sleep mode it the sensor will be in normal position otherwise it will sounds the buzzer and sends the output to the android mobile phone through Bluetooth, when the output is displayed on android mobile application the data will be synchronized to the web through using Iot of things. When data synchronization completes the data will be displayed on doctor's mobile/PC.

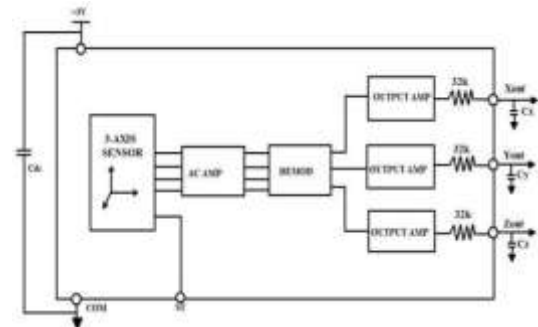

**Fig-12:** ADXL 335 functional block diagram

### [8] Saline Level Monitoring (IR Sensor)

An infrared sensor is an electronic device that emits in order to sense some aspects of the surroundings. An IR sensor can measure the heat of an object as well as detects the motion. Usually in the infrared spectrum, all the objects radiate some form of thermal radiations. These types of radiations are invisible to our eyes, which can be detected by an infrared sensor. The emitter is simply an IR LED and the detector is simply an IR photodiode which is sensitive to IR light of the same wavelength as that emitted by the IR LED. When IR light falls on the photodiode, the resistances and these output voltages, change in proportion to the magnitude of the IR light received.

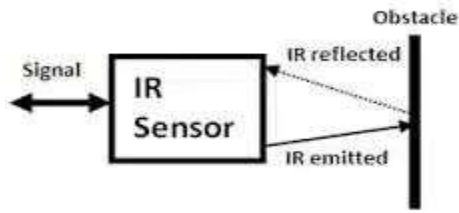

**Fig-13:** IR Sensor working

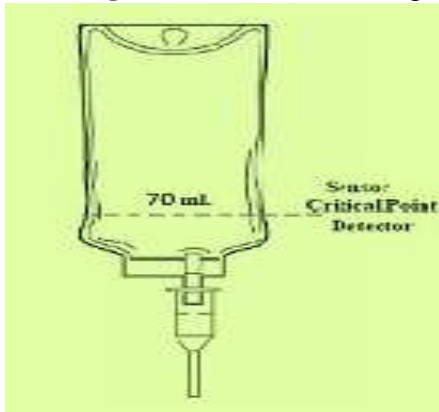
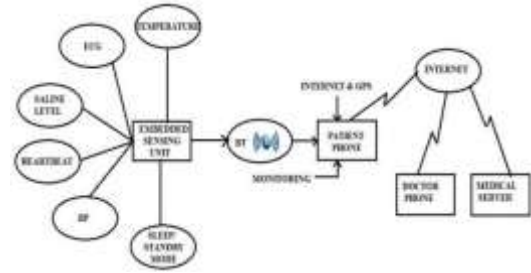

**Fig-14:** saline level monitoring

### 6. System Architecture

From the embedded healthcare monitoring system design, small, reliable, and low power medical sensor should be considered. The number and type of the medical sensors are depending on patient health state. As shown in the below figure, typical medical sensors were selected, as given in Table I, these sensors are;

- Blood pressure
- Temperature
- Heartbeat level: finger-clip pulse oximeter measures the heart beat rate.
- ECG signals
- Saline level monitoring: IR sensor can be used to alert when the saline level reaches the critical point
- Sleep/standby mode: (ADXL 335) will be used to say whether the patient is in stand or sleep position.



**Fig-15:** Layout of system architecture

### 7. Result Analysis

The proposed system was fully developed and tested to demonstrate its feasibility and effectiveness. The screenshots of the smart home app developed has been presented in Figure bellow.



**Fig-16:** Application Board



**Fig-17: Result at patient**

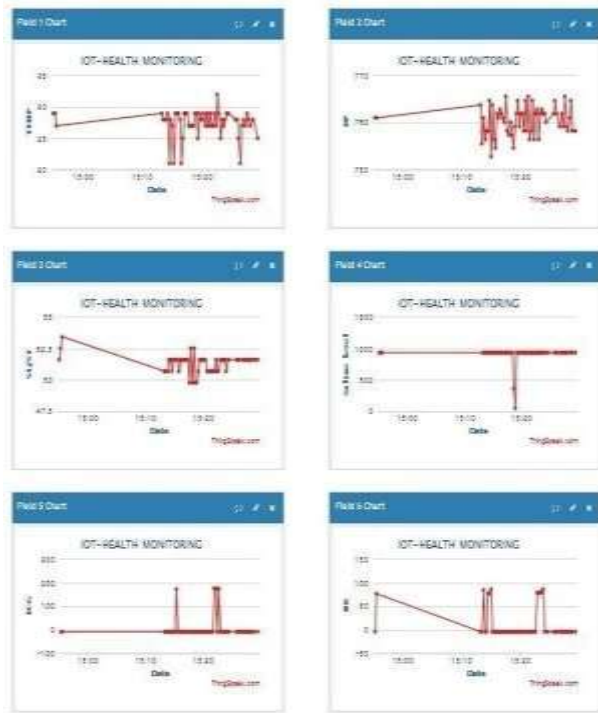

**Fig-18: Result at doctor mobile/PC**

## 8. Conclusion

In this paper, the system developed provides a remote patient health monitoring where the patient is located in a far off inaccessible location. Using IOT environment patient monitoring can be expanded to remote rural areas transport and medical care facilities not available. There is always chance to improve any system as research and development is an endless process.

## 9. References

- [1] Mukunda N.S, Thrivikrama, P.Vinay, A.Srinivas, Ajay Gupta, "A Remote Patient Monitoring System in an ADHOC Sensor Network Environment", 5th international conference on IT and Multimedia, ISBN: 978-1- 4577-0989,10th November 2011
- [2] Hongzhou Yu, Lu Liu, "Remote Health Monitoring system using Zigbee Network and GPRS Transmission Technology", 2011 Fourth International Symposium on Computational Intelligence and design, Volume 1, ISBN: 978-0-7695-4500, 4<sup>th</sup> November 2011.
- [3] Zimu Li, GuodongFeng, Fenghe Liu, Dong J.Q, Kamova.R, Tang.W, "Wireless Health Monitoring System", Applications and Technology Conference (LISAT)2010 Long Island systems, ISBN:978-1- 4244-5550, 8th October 2010.
- [5] Lodaya.P, W.Suman, "Movable patient health monitoring using GPS", Advances in Recent Technologies in Communication and Computing, 3rd International conference 2011.
- [6] K. Ramesh, S.V. AswinKumer, "Efficient Health Monitoring System Using Sensor Networks", International Journal of Scientific and Engineering research, Volume 3, Issue 6, June- 2010, ISSN:2229-5518.
- [7] Wang FengQin, Li Yang, "Zigbee Technology for Designing and Implementing a Remote Medical Monitoring System", 2010 International Conference on Computer, Mechatronics, Control and Electronic Engineering, Volume: 1, ISBN: 978-1-4244- 7956, 6th October 2010
- [8] Pantelopoulos A, Bourbakis.N.G, "A Survey on Wearable Sensor Based Systems for Health Monitoring and Prognosis", IEEE Transactions on Systems, Man and Cybernetics, Part C: Applications and reviews, Volume 40, Issue: 1, January 2010.